

RoHS Compliant HF

REV.	ECN.NO.	MODIFY.CONTENT
A	/	NEW

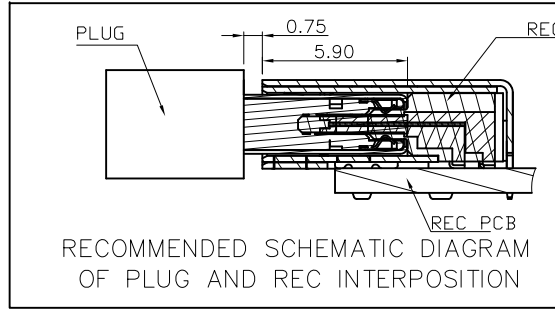
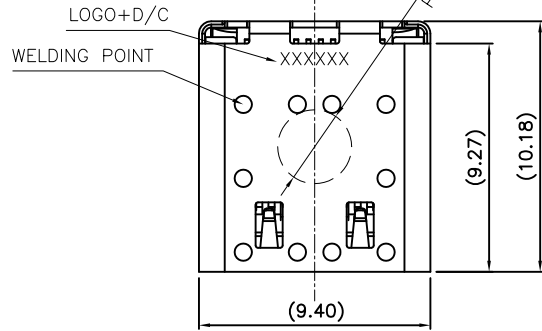

NOTES :

- ELECTRICAL :
 - CONTACT CURRENT RATING :
5A FOR VBUS (Pins A4,A9,B4,B9),1.25A FOR VCONN.
6.25A FOR GND (Pins A1,A12,B1,B12)
 - INSULATION RESISTANCE :
100 MEGAOHMS. AT 300VDC.
 - DIELECTRIC WITHSTANDING VOLTAGE :100VAC,
0.5mA LEAKAGE CURRENT MAX..
 - LOW LEVEL CONTACT RESISTANCE :
INITIAL 40mΩ MAX. AFTER LIFE 50mΩ MAX.
- MECHANICAL CHARACTERISTICS :
 - INSERTION FORCE : 5N~20N .
 - EXTRACTION FORCE : 8N~20N FROM 1 TO 30 CYCLES.
6N~20N FROM 31 TO 10000 CYCLES.
 - DURABILITY : 10,000 MATING CYCLES.
 - OPERATING TEMPERATURE : -55°C TO +85°C
 - RECOMMENDED STENCIL THICKNESS:
0.12mm min.

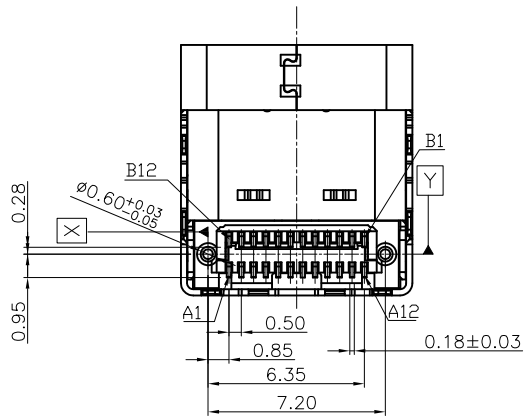
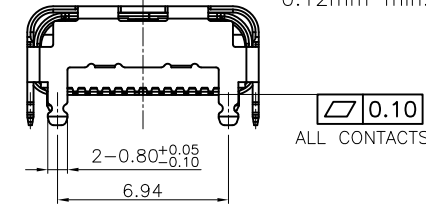
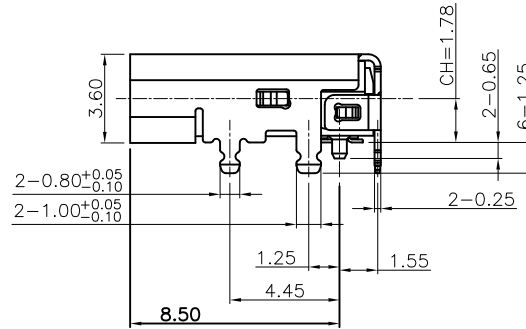
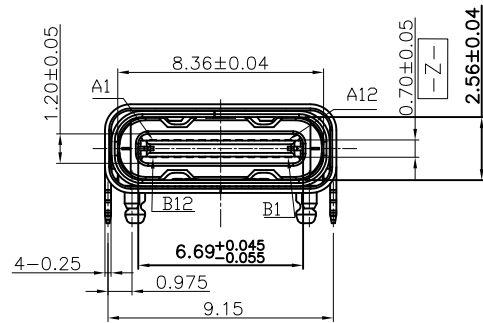

Pin	SIGNAL NAME	Pin	
A1	GND	B12	GND
A2	SSTXp1	B11	SSRXp1
A3	SSTXn1	B10	SSRXn1
A4	VBUS	B9	VBUS
A5	CC1	B8	SBU2
A6	Dp1	B7	Dn2
A7	Dn1	B6	Dp2
A8	SBU1	B5	CC2
A9	VBUS	B4	VBUS
A10	SSRXn2	B3	SSTXn2
A11	SSRXp2	B2	SSTXp2
A12	GND	B1	GND

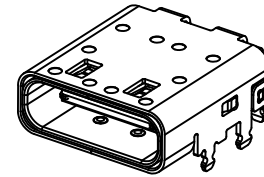

PART.NO.:
U168-CF24D014**-F

- 功能区镀金1U", 锡脚镀雾纯锡至少80U"
- 功能区镀金3U", 锡脚镀雾纯锡至少80U"
- 功能区镀金5U", 锡脚镀雾纯锡至少80U"
- 功能区镀金10U", 锡脚镀雾纯锡至少80U"
- 功能区镀金15U", 锡脚镀雾纯锡至少80U"
- 功能区镀金30U", 锡脚镀雾纯锡至少80U"

ITEM	PART NAME	QTY	MATERIAL	REMARK
⑥	TOP CONTACT	1 SET	COPPER ALLOY	50u" MIN. NI UNDER PLATING.
⑤	BOTTOM CONTACT	1 SET	COPPER ALLOY	80u" MIN. MATTE TIN PLATING ON SOLDER AREA. 1u" MIN. GOLD PLATING ON CONTACT AREA.
④	MID PLATE	1 PCS	STAINLESS	50u" MIN. NI PLATING OVERALL.
③	HOUSING	1 PCS	LCP	COLOR BLACK;UL94V-0
②	INNER SHELL	1 PCS	STAINLESS	WATER CLEANING
①	OUTER SHELL	1 PCS	STAINLESS	50u" MIN. NI PLATING OVERALL.

GENERAL TOLERANCE	DWG.NO.	U168-CF24D01442-F
x.±0.50	REV.	A
.x±0.25	SIZE	
.xx±0.15	A4	

PART.NO.	U168-CF24D014**-F	DRAWN	YZQ 2023.08.08
TITLE	TYPE-C 24PIN CH=1.78	CHECKED	
SHEET	1 OF 2	APPROVED	

UNIT	mm	SCALE	1:1
东莞市欧联电子科技有限公司 DONGGUAN OLN ELECTRONICS TECHNOLOGY CO., LTD.			

REV.	ECN.NO.	MODIFY.CONTENT
A	/	NEW

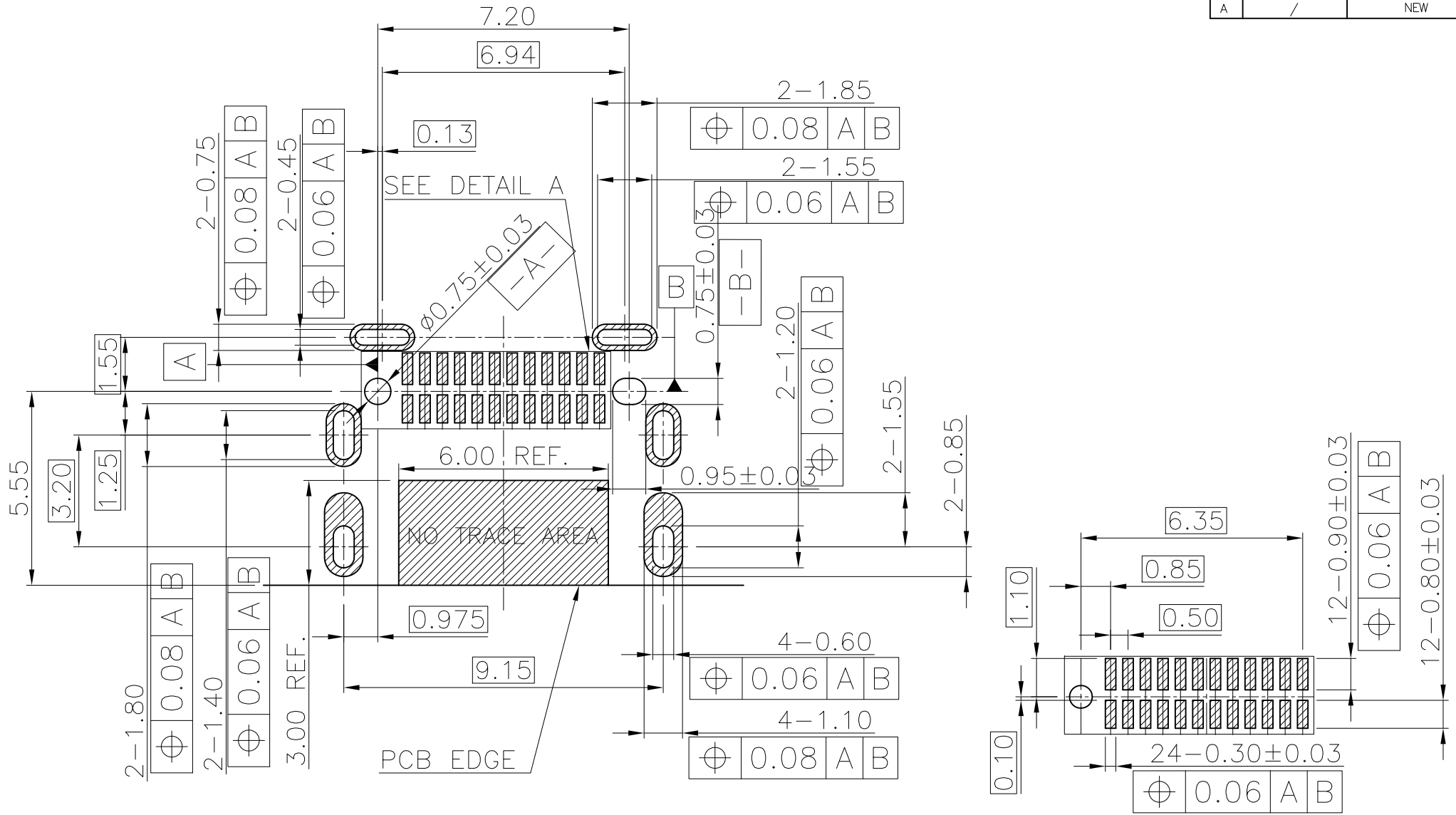

RECOMMENDED PCB LAYOUT
 GENERAL TOLERANCE ±0.05

GENERAL TOLERANCE	DWG.NO.	U168-CF24D01442-F	PART.NO.	U168-CF24D014**-F	DRAWN	YZQ 2023.08.08
x.±0.50	REV.	A	TITLE	TYPE-C 24PIN CH=1.78	CHECKED	
.x±0.25	SIZE	A4	SHEET	2 OF 2	APPROVED	
.xx±0.15						

UNIT	mm	SCALE	1:1
 东莞市欧联电子科技有限公司 DONGGUAN OLN ELECTRONICS TECHNOLOGY CO., LTD.			